

PART#: 81SV90 & 81SV70



9000

7000



INTRODUCES OUR
NEW CYCLONIC
SUPERVAC™ POWER
UNITS WITH IMPROVED
FILTER SYSTEMS AND
QUIETER OPERATION

THE ALL NEW SUPERVAC™ 9000 & 7000

Hayden SuperVac™ 9000

Part #: 81SV90

Motor: 2-Stage

Air Watt: 620

Vacuum (Water Lift): 144"

Air Flow: 126 CFM

Filtration System:

Primary: Cyclonic Separation

Secondary: Washable Cartridge Filter

Warranty:

Motor and Internal Electrical

Components: 10 Years * (Limited)

* See reverse for details

Note: Washable Foam Filter **81SV90FF**

Hayden SuperVac™ 7000

Part #: 81SV70

Motor: 2-Stage

Air Watt: 550

Vacuum (Water Lift): 128"

Air Flow: 114 CFM

Filtration System:

Primary: Cyclonic Separation

Secondary: Washable Cartridge Filter

Warranty:

Motor and Internal Electrical

Components: 7 Years

Note: Washable Foam Filter **81SV70FF**

canplas®

Canplas Industries Ltd.
P.O. Box 1800, 500 Veterans Drive
Barrie, Ontario
Canada L4M 4V3
Tel: (705) 726-3361
Toll Free: 1-800-461-5300
Fax: (705) 726-2186

Canplas LLC
11402 East 53rd Ave.
Suite 200, Denver, CO
U.S.A. 80239
Tel: (303) 373-1918
Toll Free: 1-888-461-5307
Fax: (303) 373-1923

We reserve the right to make part modifications without prior notice.

an OAliaxis company

www.canplas.com



THE ALL NEW SUPERVAC™ 9000 & 7000

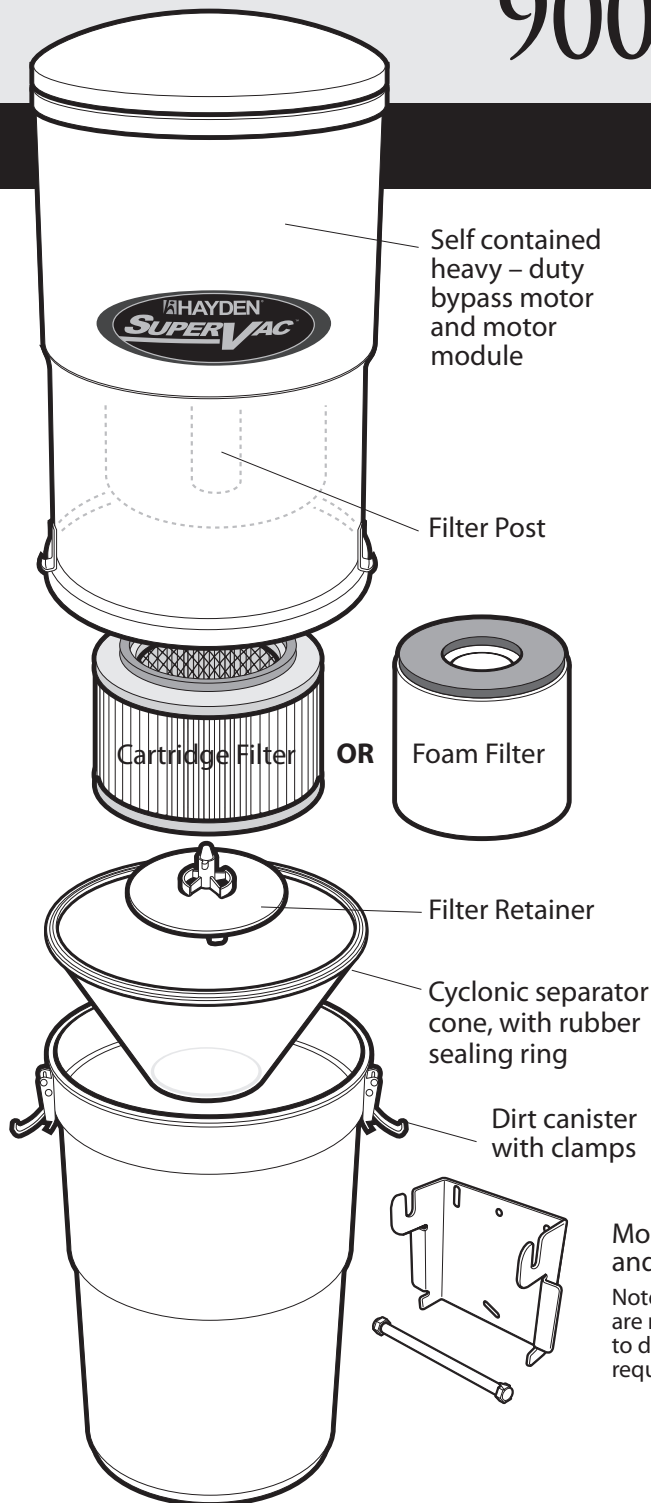

Hayden SuperVac™ 9000 / 9000FF

Part #: 81SV90 / 81SV90FF

Warranty:

*(Limited) For the first 7 years, Canplas will be 100% responsible for the warranty, including parts and labour. For the following 3 years, Canplas will be responsible for 50% of the parts and labour cost, and the owner is responsible for the other 50% of the parts and labour cost.

Note: Filters & Motor Brushes are considered normal wear and tear items and are not covered under the warranty.

Mounting bracket and mounting bar

Note: (bolts or screws are not provided due to different installation requirements)



Mixed Sources

Product group from well-managed forests and other controlled sources
www.fsc.org Cert no. SGS-COC-006015
© 1996 Forest Stewardship Council

canplas®

Canplas Industries Ltd.
P.O. Box 1800, 500 Veterans Drive
Barrie, Ontario
Canada L4M 4V3
Tel: (705) 726-3361
Toll Free: 1-800-461-5300
Fax: (705) 726-2186

Canplas LLC
11402 East 53rd Ave.
Suite 200, Denver, CO
U.S.A. 80239
Tel: (303) 373-1918
Toll Free: 1-888-461-5307
Fax: (303) 373-1923